

HIGHDESK

Electric Height Adjustable Desk 2-Leg Pro

User Guide

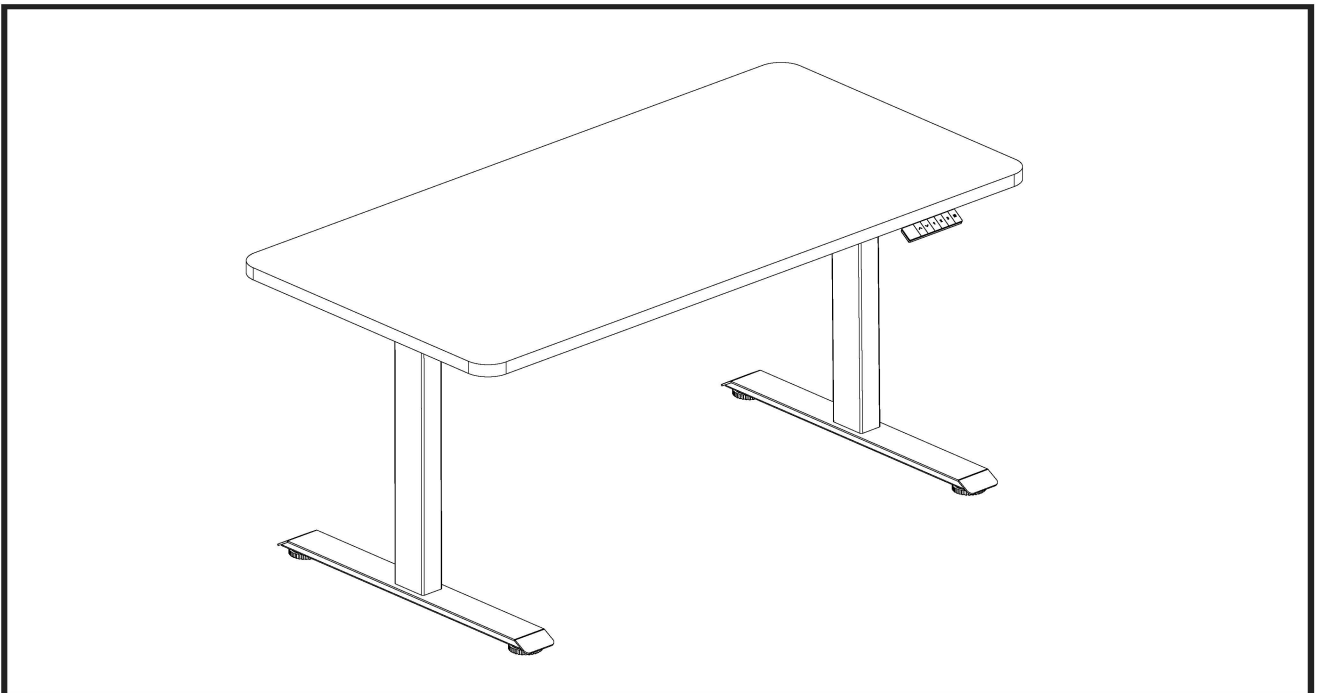

CAUTION

MAKE SURE NO OBSTACLES ARE IN THE DESK'S PATH AND ALL CORDS ARE OF APPROPRIATE LENGTH FOR DESK TRAVEL. FAILURE TO COMPLY WITH OR OBSERVE ALL ASSEMBLY, SAFETY, AND OPERATION INSTRUCTIONS AND WARNINGS REGARDING THE USE OF THIS PRODUCT MAY RESULT IN SERIOUS PROPERTY DAMAGE OR BODILY INJURY.

IMPORTANT

Any user or installer of desk base must study this manual carefully.
If this desk is sold, please provide the manual to the buyer.

▲ CAUTION:

SAFETY AND WARNINGS

- Inappropriate use of this product may cause property or bodily damage.
- Check the surroundings on all sides before using the desk. Make sure the desk does not touch the wall.
- Please unplug the power supply during lightning and when the product is not in use for a long time.
- Make sure NO obstacles are in the desk's path and no obstacles higher than 500 mm under the desk.
- Keep the work environment temperature at 0-40 °C. And keep goods away from corrosive gases, liquids, and dusty objects.
- Ensure the length of power cords is accounted for when operating the desk. Monitors, computers, speakers, and anything with a cord that is not long enough for the desk's range of motion could be pulled down.
- Please provide this operation manual to any users, installers, or support personnel operating the product. Read relevant operating instructions before using. The company does not take any responsibility for damage caused by the abnormal operations.

USAGE

This desk is height adjustable so that it can be positioned at the most ergonomically suitable height. These desks are designed only for the purposes included in this manual. They should not be used in environments with high humidity or dampness. Any other use is at the user's risk.

Do not move around, crawl or lie under the desk frame. Do not sit or stand on the desk frame.

Liability: Under no circumstances does the manufacturer accept warranty claims or liability claims for damages caused by improper use handling of the desk frame.

SETUP AND INSTALLATION

Once the desk has been assembled, adjust the feet so that the desk is level. After this, connect the desk to the 110v or 240v outlet and the desk is ready for use.

Check that no cables are jammed.

Position the desk a safe distance from window frames, furniture, etc. So that items don't get stuck or trapped by the desk.

Do not place any objects that are taller than 50cm(20") underneath the desk. After it has been assembled, when moving the desk, DO NOT lift the desk by the desktop. Lifting this way can stress the fasteners connecting the desk base to the desktop. Lower the desk completely and lift the desk by grabbing the top of the desk base or by removing the desktop first.

1. PARTS LIST

Tools Required

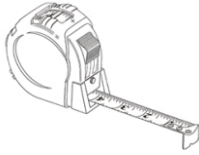

Tape Measure



Philips Head Screwdriver

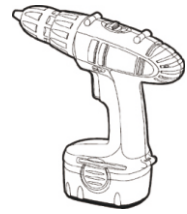

Power Drill

Components

1

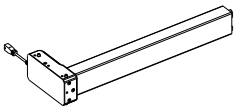

Lifting Column *2

2

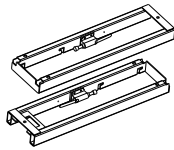

Crossbar End *2

3

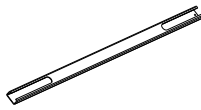

Crossbar Center Rails *2

4

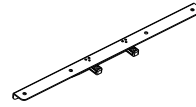

Side Bracket *2

5

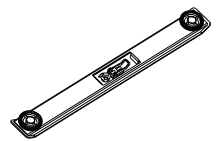

Foot *2

6

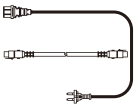

Wires *2

7

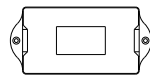

Control Box *1

8

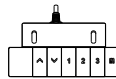

Handset *1

Hardware

A

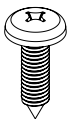

Qty 10
M5X18
Screws

B

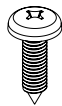

Qty 2
M4X12
Screws

C



Qty 5
Cable
Clips

D



4mm
Allen
Key

2. ASSEMBLY INSTRUCTIONS

1 Pull out the frame

- a** Loosen the screws first.
- b** Stretch the frame to the desired length.
- c** Tighten the screws.

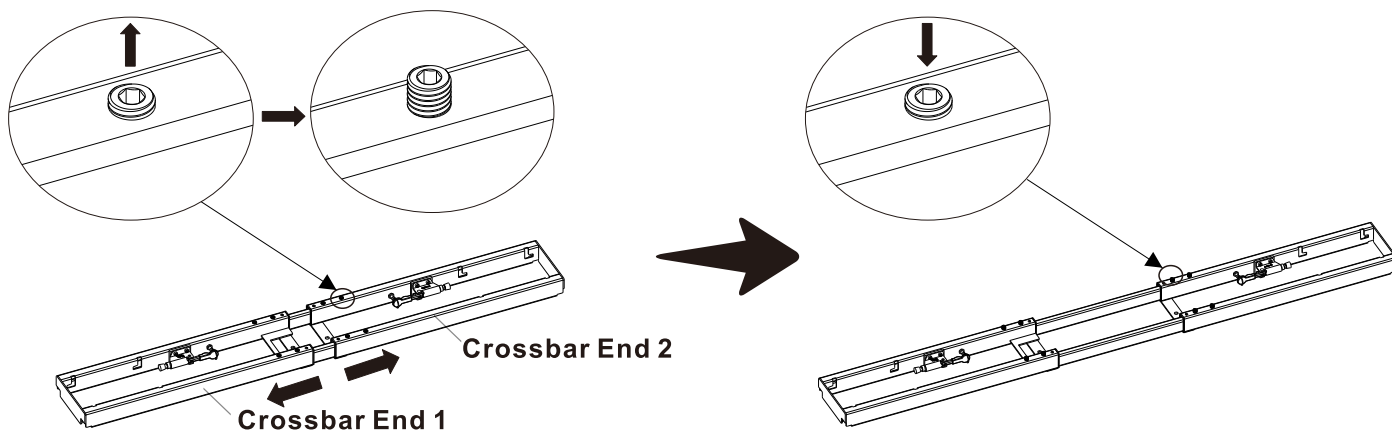

! Avoid over-tightening the screws to damage the product.

2 Attach legs to Frame

- a** Insert leg into beam and slot into position.
- b** Use fast-install component, and quick latch to secure the leg, the components will automatically tighten the leg.

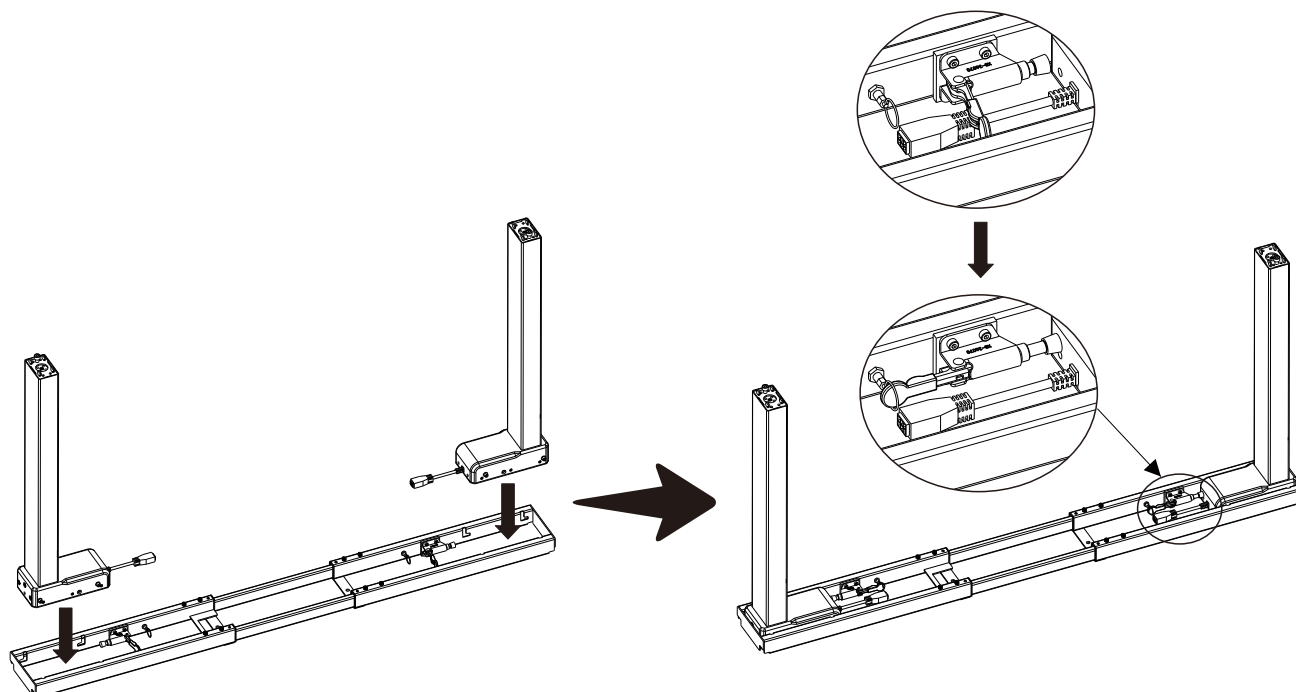

3 Attach Side Bracket

- a The side panel snaps onto the frame .

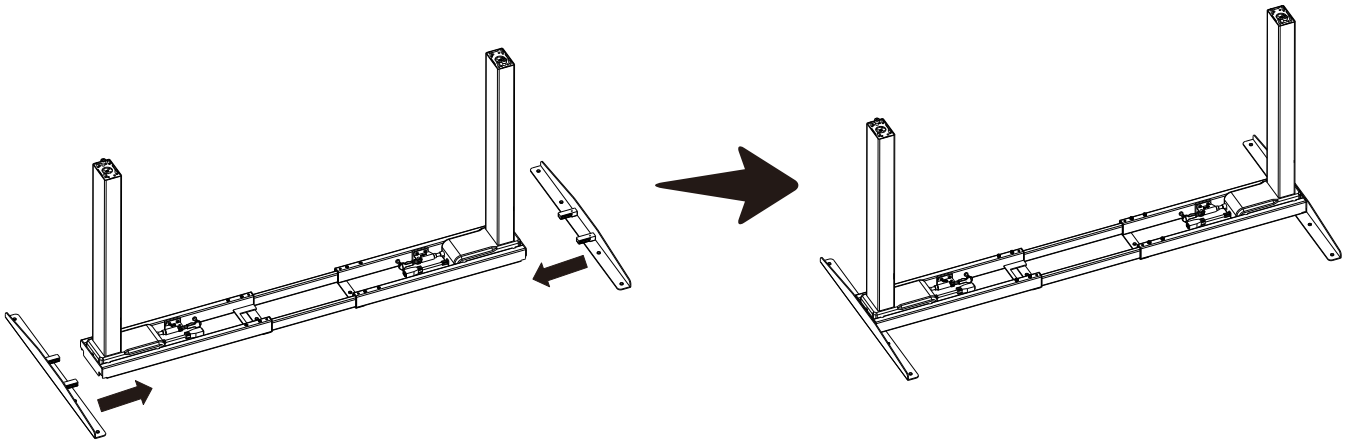

4 Attach Foot

- a Put the foot on the column.
- b Use fast-install component ,to clamp the foot into position.

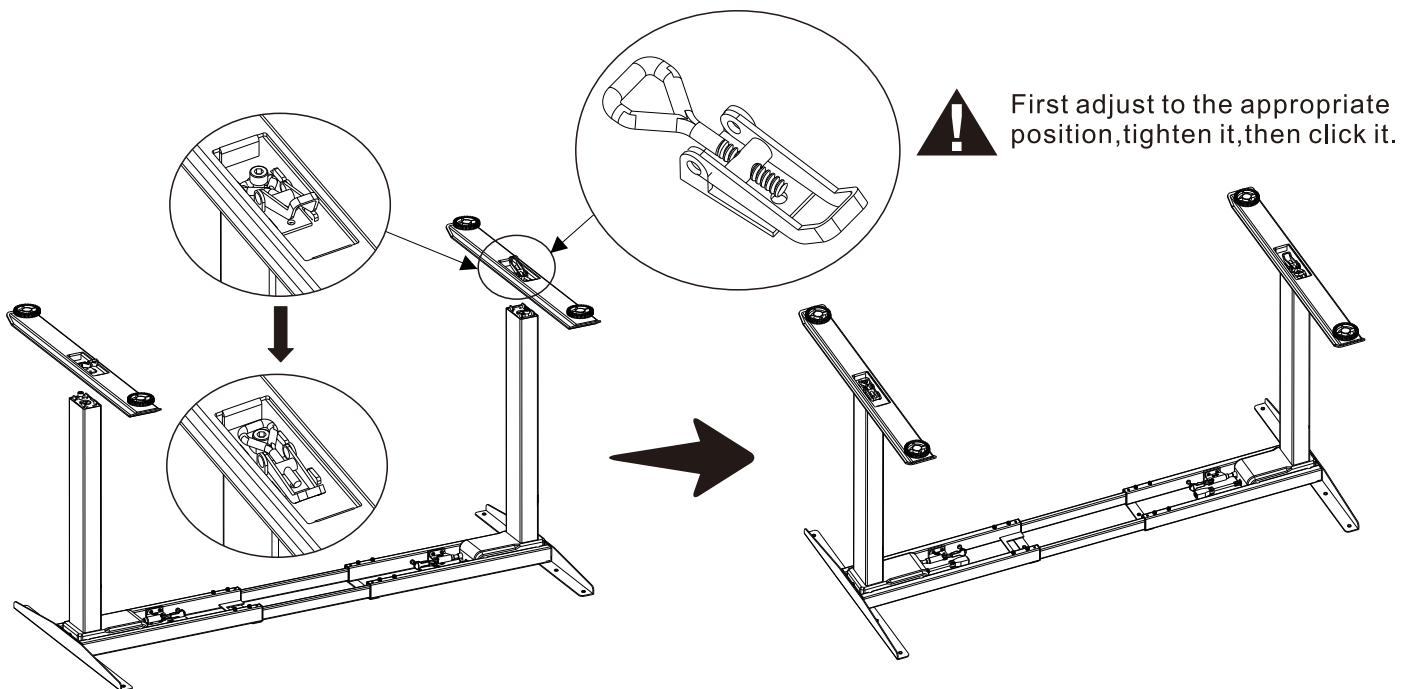

5 Attach Frame Set to Worktop

- a Fix the worktop and frame with M5×18 mm screws(A).

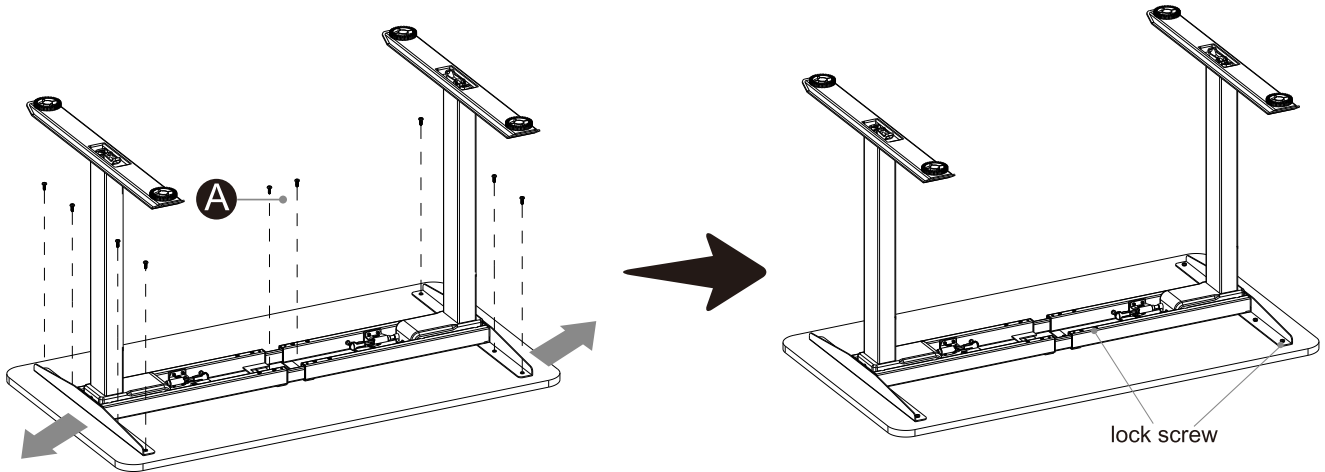
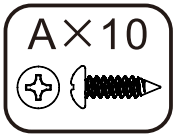

The length of the frame can be adjusted by lifting the two side brackets. The adjustable range is 1010~1750 mm.

Avoid over-tightening the screws.

6 Attach Control Box & Handset

- a Insert the Control Box(7) controller into the crossbar.
- b Attach the Handset(8) to the worktop plate with M4×12mm(B) screws.

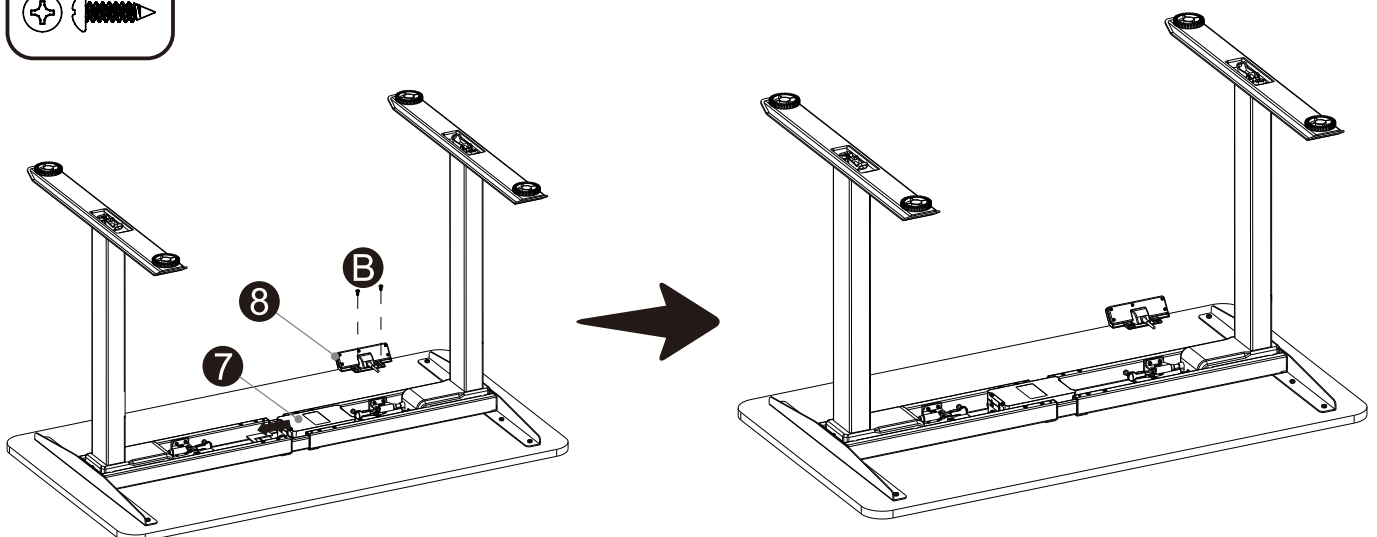
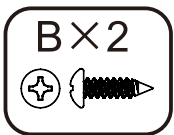

Avoid over-tightening the screws.

7 Attach Connect Cables

- a Connect the lead from lifting column 1 to Control Box(7)M1. Connect the lead from the other lifting column to Control Box(7)M2.
- b Connect the Handset (8) to the Control Box(7) HS port.
- c Connect power cable (6) to Control Box(7) AC port.

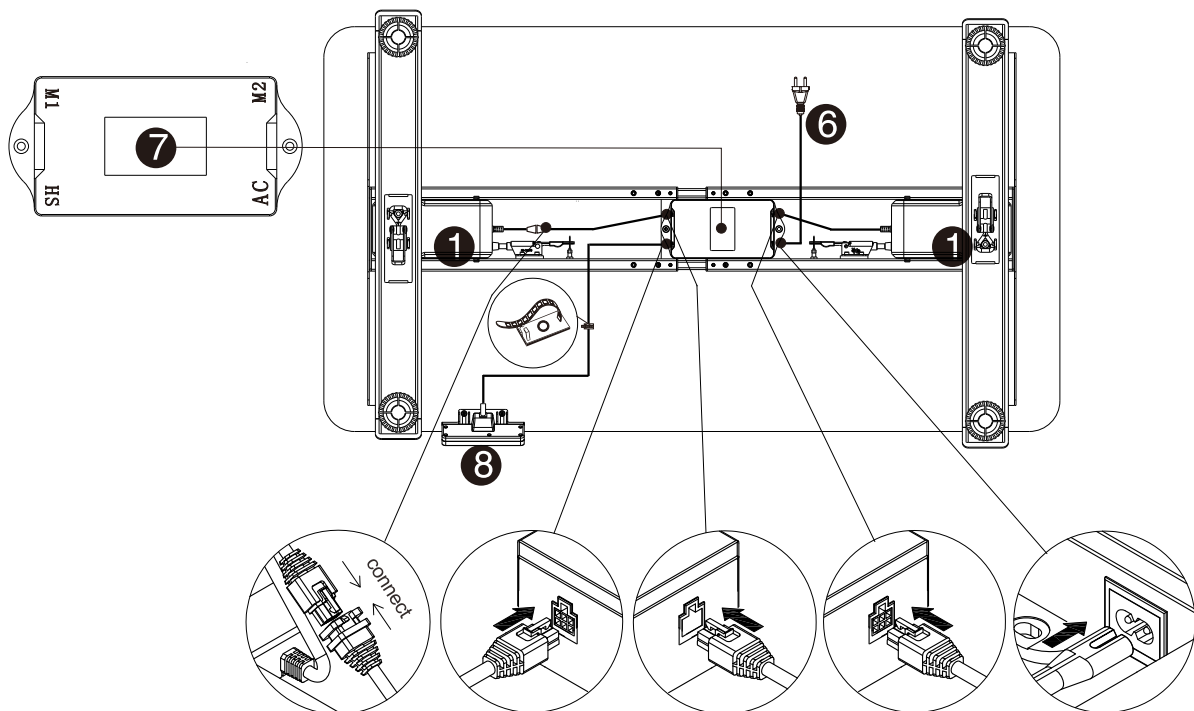

8 Put desk Upright and Connect Power Cord to the Power Supply

- a** With the desk at its lowest height, turn the assembled desk right-side up with the help of at least two people.
- b** Plug the Power Cord(6) into 110-240v outlet.

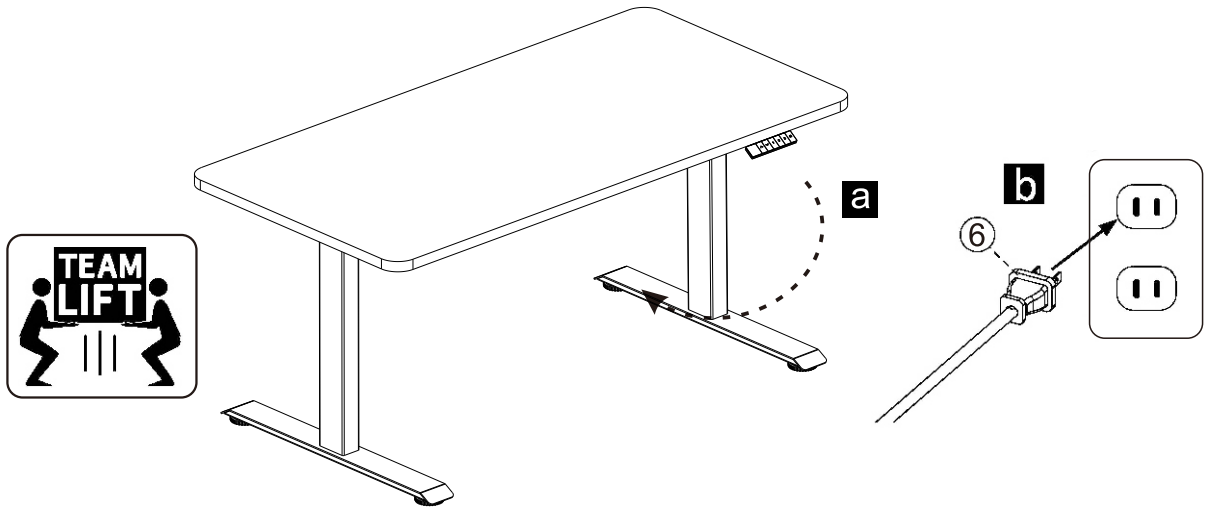

NOTE: Grab the desk Frame (not the desktop and turn the desk right-side up).

9 Adjust Leveling Studs

If necessary, adjust the leveling feet to level the desk.
Unscrew to increase height, screw in to decrease height.

10 Initialize

- a** Press "∨" button until desk reaches the lowest position.
- b** Press "∨" five seconds until there is a beep sound heard, the desk reset is successful.
Your desk is ready to use.



You must complete this initialization step or your workcenter will NOT function properly.

Hold down the down arrow until worktop moves slightly upwards!

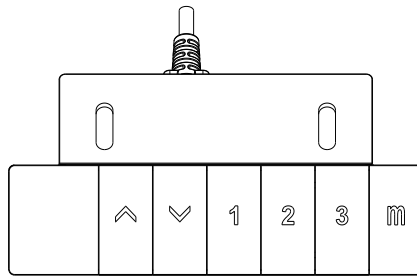

Initialize/Reset

If “RST” is shown in the display, the lifting table must be reset or reinitialized.

Press the < DOWN button > until the desk reaches the lowest position. Press the <AB button> for 5 seconds until you hear a beep.

Danger! (hold down the <DOWN key> until the worktop moves slightly up again). The desk has been initialized or the reset has been carried out successfully and the desk is ready for use.

Note: For all resets, the anti-collision system fails at this time. Please make sure that there are no obstacles near the table during initialization or reset to prevent danger.

• UP and DOWN

1. ^ • Press “^” key to adjust ascending height freely.
2. v • Press “v” key to adjust descending height freely.

• Location storage and memory operation

▲ By memorizing the position setting, you can easily reach the position you want with one click. (Two key switches do not have this function)

1. ^ v • Ascend or descend to your desired height.
2. M • Press and hold the M key until show “S-”
3. 1 • Press the “1” key to complete the setting of the first memory. (“2” key and “3 key” are the same as above)









• Anti-collision protection

▲ Before using this product, check for obstacles and remove them in advance.

- When the tabletop encounters an obstacle in the process of ascending or descending, it will immediately rise or fall in the opposite direction.
- The tabletop runs in reverse for some distance and works normally after removing the obstacle.





• Minimum and maximum limit setting

⚠ Do not set this function unless necessary.

1.   • Hold the “M” + “∨” button at the corresponding height for 5 seconds, then you will hear the buzzer sound, indicating that the lowest position is successfully stored.
2.   • Hold down the “M” + “∨” button for 5 seconds, at this time you will hear the buzzer sound, indicating that the lowest position storage is canceled.
3.   • Hold the “M”+“^”button for 5 seconds, you will hear the buzzer sound, indicating that the highest position is stored successfully.
4.   • Hold down the “M” + “^”button for 5 seconds, you will hear the buzzer sound, indicating that the highest position storage is canceled.

⚠ Note: By applying this function to adjust the movement limit position of the table top, once set, the new lowest position and highest position will be archived. Buzzer sound, indicating that the highest position storage is canceled.

• Locking and unlocking child locks

1.   • Locking: Hold “^”+“∨” for 5 seconds at the same time, when the digital tube shows “Loc”, this time indicates that the system has been locked. Cannot do lifting operation on the system.
2.   • Unlock: Hold “^”+“∨” for 5 seconds at the same time, when the digital tube is displayed from Loc to the normal digital display, indicating that the system has been unlocked.

• Internal parameters and installation distance settings

 Press and hold the M button (approx, 10 seconds) to access the settings menu. You can select and change another setting parameter by pressing the S button. To change the settings, press the Up or Down button. Save the set parameters by pressing and holding the M button for 10 seconds.

Caution

If you do not make any, changes during the setting for approx, 10 seconds the settings menu will close again without saving the parameters.

1. Unit of measurement 0 for cm / 1 for inch
2. Collision sensitivity specifies the collision sensitivity of the gyro sensor
0= switched off (not recommended)
1= most sensitive
8= least sensitive
3. Collision sensitivity indicates the collision sensitivity during start-up
0= switched off (not recommended)
1= most sensitive
8= least sensitive
4. Collision sensitivity indicates the collision sensitivity when lowering
0= switched off (not recommended)
1= most sensitive
8= least sensitive

5. Collision sensitivity indicates the collision sensitivity when raising

0= switched off (not recommended)
1= most sensitive
8= least sensitive

63

Adjustment with the table top thickness. The display shows the setting with the top edge of the table.

You can change the value using the UP and DOWN buttons.
Default = 63

7. Operating mode



0= constant touch (recommended)

- Automatic movement of the table is switched off

1= single touch

- Automatic movement of the table is switched on

Error messages on the handset 's display

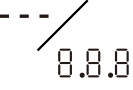
Error code	Possible cause	Solution
	High power temperature	Wait for 18mins or unplug the desk for 15seconds then plug it again
	There is an internal error in the control unit.	Unlock the desk, keep pressing the up and down button together till the loc disappears.
	Bad connect	Check the Handset and Control Box properly plugged, if not work Change the Handset or Control Box.
Blank screen	No connect	Check the plug are properly plugged, if not work please plug Handset or Control Box.
E4	Hand controller communication error	Check the manual line
E6	Failure of main power start	Replace the main power supply or check the main power connection
E7	Protection while main power is running	Power up again
E8	Tilt while the desktop is running	Reinitialization
E11	Motor 1 Unconnected	Check the connection
E13	Motor 1 Lack of phase, phase line disconnected	Check the motor for abnormal connection
E14	Motor 1 Hall error, or disconnect of Hall line	Check the Hall signal, or replace the connection
E16	Motor 1 shutoff	Reinitialization
E21	Motor 2 not connected	Check the connection
E23	The motor 2 lacks phase and the phase line	Check the motor for abnormal connection
E24	Motor 2 Hall error, or disconnect of Hall line	Check the Hall signal, or replace the connection
E26	Motor 2 shutoff	Reinitialization
E36	Motor 3 shutoff	Reinitialization
E42	Memory error	Replacement of controllers
E43	Stop sensor error	Replacement of controllers